

Hand test pump, pneumatic Model CPP30

WIKA data sheet CT 91.06



for further approvals
see page 2

Applications

- Simple test pressure generation on site, in the laboratory or in the workshop
- For the testing, adjustment and calibration of all types of pressure measuring instruments
- Pneumatic pressure generation from -0.95 ... +35 bar (-28 inHg ... +500 psi)

Special features

- Ergonomic handling
- Precise setting through the fine adjustment valve
- Compact dimensions
- Low weight



Hand test pump model CPP30

Description

Application areas

Hand test pumps serve as pressure generators for the testing, adjustment and calibration of mechanical and electronic pressure measuring instruments through comparative measurements. These pressure tests can be carried out in the laboratory or workshop, or on site at the measuring point.

Easy operation

If one connects the test item and a sufficiently accurate reference measuring instrument to the hand test pump, on actuating the pump, the same pressure will act on both measuring instruments. By comparison of the two measured values at any given pressure value, a check of the accuracy and/or adjustment of the test item can be carried out. In order to approach the measuring points exactly, the hand test pump features a fine adjustment valve.

Easy handling

The model CPP30 hand test pump, despite its very compact dimensions, enables a simple and accurate test pressure generation of up to 35 bar (500 psi), with an switchover to vacuum generation of down to -950 mbar (28 inHg). The maximum pressure or vacuum achievable is dependent upon the connected test volume.

For the precise setting for accurate comparative testing, the pump features a fine adjustment valve. The reference instrument is screwed directly to the top of the pump, and the test item is connected using a connecting hose with a G 1/4" female thread, included in delivery.

Specifications	Model CPP30
Pressure range	-0.95 ... +35.0 bar (-28 inHg ... +500 psi)
Pressure transmission medium	Air
Pressure connections	G ½ female thread for reference instrument, freely rotating; hose with G ¼ female thread for test item, freely rotating Option: adapter to 1/4" NPT female thread for reference instrument connection
Fine adjustment	Fine adjustment valve
Overpressure protection	Adjustable via knurled nut
Material	Chrome-plated brass, anodised aluminium, high-strength plastic
Dimensions (L x W x H)	220 x 105 x 63 mm (8.66 x 4.31 x 2.48 in)
Weight	510 g (1.125 lbs)

Approvals

Logo	Description	Country
	EAC Machinery directive	Eurasian Economic Community
-	MTSCHS Permission for commissioning	Kazakhstan

Dimensions in mm (in)

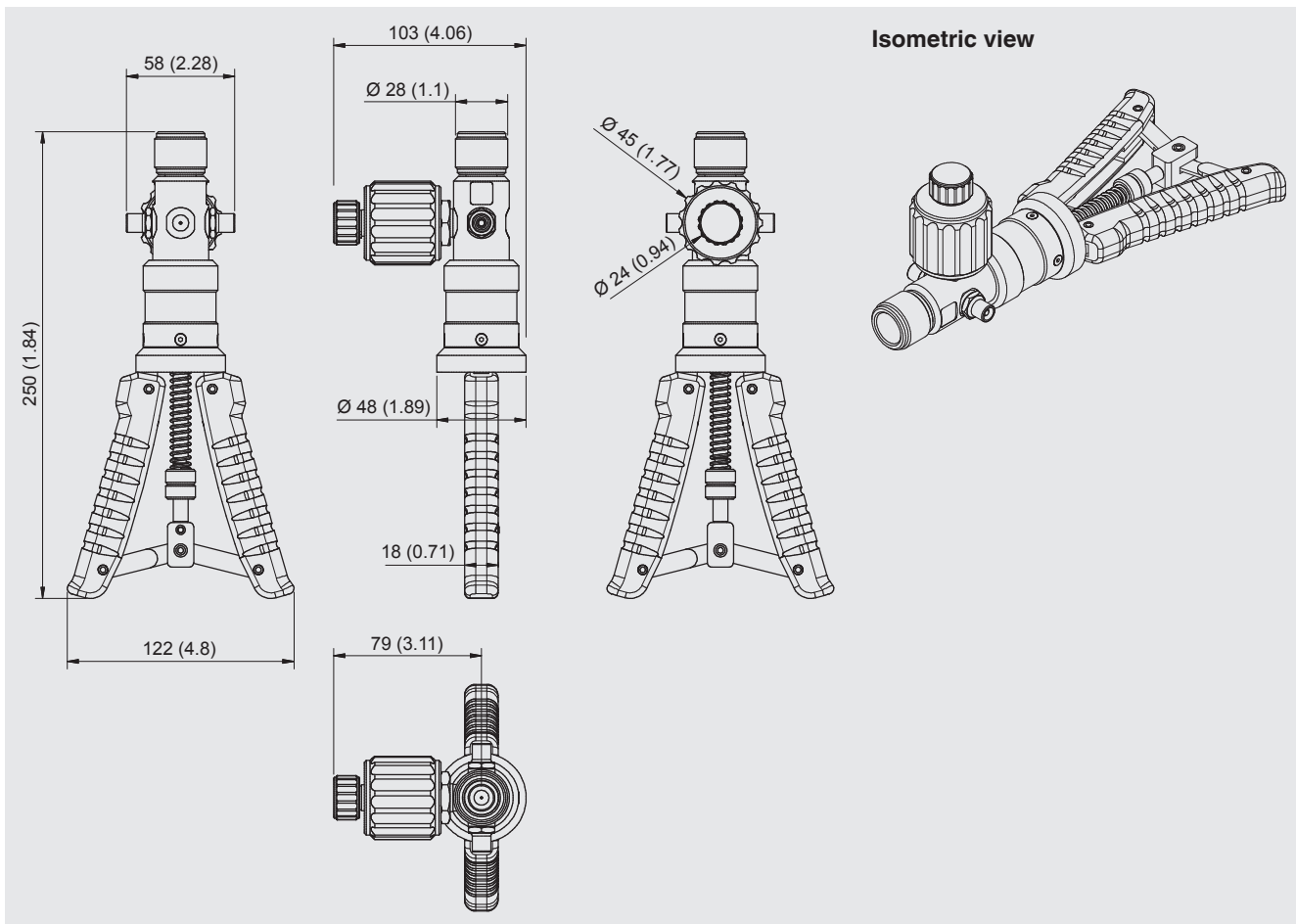

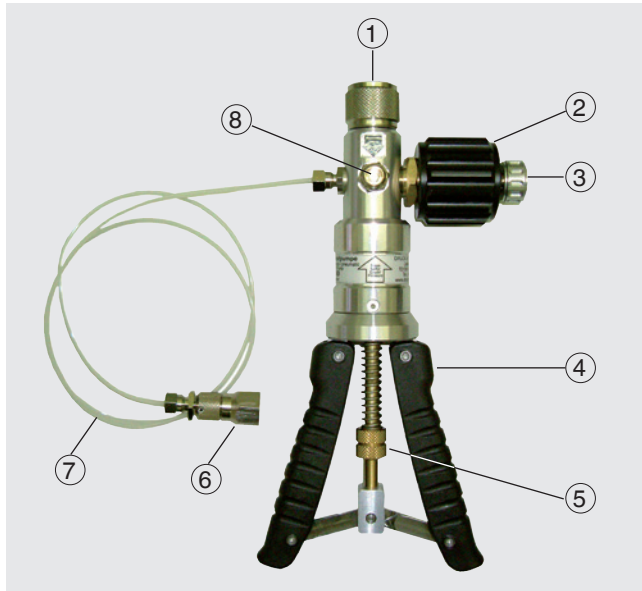

- ① Pressure connection for reference measuring instrument, G ½ female thread, freely rotating
- ② Fine adjustment valve
- ③ Pressure relief valve
- ④ Pump handle
- ⑤ Adjustable knurled nut for setting the pump performance
- ⑥ Pressure connection for test item, G ¼ female thread, freely rotating
- ⑦ Connecting hose; length 0.5 m (1.64 ft)
- ⑧ Switchable pressure/vacuum generation

WIKA-Cal calibration software for creating calibration certificates or logger protocols

For specifications see data sheet CT 95.10



Calibration case

Consisting of:

- Pneumatic hand test pump model CPP30
- Standard accessories see scope of delivery

Scope of delivery

- Model CPP30 hand test pump
- Test item hose; length 0.5 m (1.64 ft) incl. connection adapter G ¼ female, freely rotating
- Operating instructions

- Connection adapter: G ¼ male to G ½ female, material: stainless steel

Case

- Plastic case, incl. foam insert with free spaces for model CPP30;
- Dimensions (W x H x D): 350 x 295 x 106 mm (13.78 x 11.61 x 4.17 in)

Accessories

Adapters

- Adapter set "BSP" for test item hose, G ¼ male to G ⅛, G ⅜ and G ½ female
- Adapter set "metric" for test item hose, G ¼ male to M12 x 1.5, M20 x 1.5 and Minimesse®
- Adapter set "NPT" for test item hose, G ¼ male to ⅛ NPT, ¼ NPT, ⅜ NPT and ½ NPT female

Other

- Maintenance set for CPP30 hand pump with different O-rings and seals
- Spare hose for model CPP30; length 0.5 m (1.64 ft) G ⅛ male to G ¼ female, freely rotating
- Spare hose for model CPP30; length 1 m (3.28 ft) G ⅛ male to G ¼ female freely rotating

CPP30 / Pressure connection kit / Adapter set / Case / Accessories / Further approvals / Additional ordering information