

EE364

Moisture in Oil Sensor

The compact moisture in oil sensor is designed for reliable online monitoring of the moisture in transformer, engine, lubrication or hydraulic oil as well as in diesel fuel. Besides the accurate measurement of water activity (aw) and temperature (T), the EE364 calculates the absolute water content (x) of the oil in ppm.

Outstanding Measurement Performance

The sensor employs high end E+E humidity sensing elements which feature outstanding long term stability and high resistance to pollution.

Functional Design

The small size and robust stainless steel enclosure, together with the choice of process connections allow easy and space-saving installation.

Analogue and Digital Outputs

The aw, T and x measured data is available on two freely configurable 4 - 20 mA analogue outputs and on the RS485 interface with Modbus RTU protocol. The wide scaling range of the analogue output facilitates the EE364 implementation in existing monitoring and control systems.

Configurable and Adjustable

The setup and adjustment of the EE364 can be easily performed with an optional configuration adapter and the free EE-PCS Product Configuration Software.



Features

Measurement performance

- » Water activity (aw), water content (x), temperature (T)
- » Oil temperature -40...100 °C (-40...212 °F)
- » Suitable for transformer, lubrication and hydraulic oil, as well as for diesel fuel

Configurable and adjustable

- » Service interface
- » Free configuration software

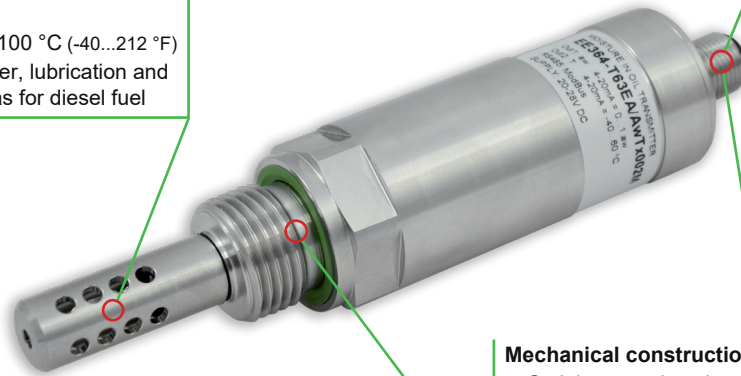

Outputs

- » 2 x 4 - 20 mA output, wide scaling range
- » Modbus RTU
- » Industrial M12x1 connector

Mechanical construction

- » Stainless steel enclosure and filter cap
- » Pressure tight up to 20 bar
- » Process connection with ISO or NPT thread
- » IP65/NEMA 4

Inspection certificate according DIN EN 10204-3.1

Measurement of water activity a_w /water content x

The moisture in oil can be expressed in absolute or relative terms.

Water activity a_w is a relative measure for moisture in oil. It represents the ratio between the actual amount of dissolved water and the maximum possible amount of dissolved water in the oil at a given temperature. The a_w value indicates how close to saturation is the oil. $a_w = 0$ means dry oil (no water at all), $a_w = 1$ means fully saturated oil. Water activity does not depend on the type of oil.

Water content x is an absolute measure for the amount of water in the oil (dissolved, emulsified or separated). The water content is usually expressed in ppm or mg water/kg oil and it is independent from the oil temperature. For assessing the degree of saturation, x must be regarded together with T .

EE364 calculates x based on the measured a_w and T values. The calculation is oil dependent and requires a set of oil specific parameters. E+E offers the service of determining the oil specific parameters, see section "Accessories" below. The parameters can be set upon order or uploaded to EE364 using the EE-PCS Product Configuration Software.

Technical data

Measurands

Water activity (a_w)/water content (x)

Working range	0...1 / 0...100 000 ppm (ppm output is valid in the range 0...100 °C (32...212 °F))
Accuracy ¹⁾ at 20°C (68 °F)	±0.02 ($a_w = 0...0.9$) ±0.03 ($a_w = 0.9...1$)
Response time t_{90} at 20°C (68 °F), in still oil, typ.	10 min.

Temperature

Maximum working range	-40...100 °C (-40...212 °F)
Accuracy ¹⁾ at 20°C in oil	±0.2 °C (0.36 °F)
Resolution	0.01 °C (0.18 °F)

Output

Analogue output (scalable)	2 x 4 - 20 mA (3-wire) RL < 500 Ohm
Resolution	2 µA
Digital interface	RS485 (EE364 = 1 unit load)
Protocol	Modbus RTU
Default settings	Baud rate 9600 ²⁾ , parity even, 1 stop bit, Modbus address 234

General

Power supply class III ³⁾ 	10 ³⁾ - 28V DC ^{*)} 10V+0.02*R _L
Power consumption	<20 mA + load current
Electrical connection	M12x1 plug 8 poles
Pressure rating	0...20 bar (0...290 psi)
Enclosure material	Stainless steel 1.4404 (AISI 316L)
Protection rating	IP65/NEMA 4
Filter	Stainless steel
Oil temperature	-40...80 °C (-40...176 °F) / -40...100 °C (-40...212 °F)
Ambient temperature	-40...60 °C (-40...140 °F) / -40...80 °C (-40...176 °F)
Storage temperature	-40...60 °C (-40...140 °F)
Electromagnetic compatibility	EN 61326-1 EN 61326-2-3 Industrial environment FCC Part15 Class A ICES-003 Class A



- 1) The accuracy statement includes the uncertainty of the factory calibration with an enhancement factor $k=2$ (2 x standard deviation). The accuracy was calculated in accordance with EA-4/02 and with regard to GUM (Guide to the Expression of Uncertainty in Measurement).
- 2) Supported baud rates: 9 600, 19 200 and 38 400; find more details about communication setting in the User Manual and the Modbus Application Note at www.epluse.com/EE364.
- 3) USA & Canada class 2 supply required.

Dimensions

Values in mm (inch)

ISO thread

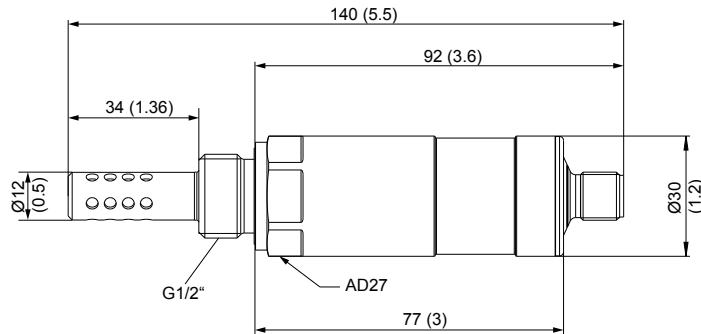

NPT thread

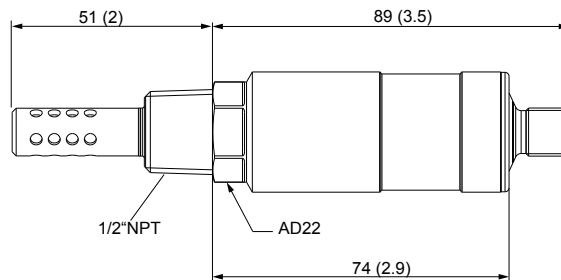

Ordering Guide

			EE364-
Hardware	Process connection	G 1/2" ISO thread 1/2" NPT thread	PA1 PA2
	Fluid temperature	-40...80 °C (-40...176 °F) -40...100 °C (-40...212 °F)	HM1 HM2
	Filter	Stainless steel, for flow < 1 m/s (< 3.28 ft/s) Stainless steel, for flow > 1 m/s (> 3.28 ft/s)	F13 F18
	Accessories	No accessories M12x1 cable socket, for self assembly	AC0 AC2
	Output 1	Water activity aw [] Water content x [ppm] Temperature T [°C] Temperature T [°F]	no code MA70 MA1 MA2
Software Setup - Analogue Outputs	Scaling 1 low	0 Value	no code SALValue
	Scaling 1 high	1 Value	no code SAHValue
	Output 2	Temperature T [°C] Temperature T [°F] Water activity aw [] Water content x [ppm]	no code MB2 MB67 MB70
	Scaling 2 low	-20 Value	no code SBLValue
	Scaling 2 high	80 Value	no code SBHValue
	Units (Modbus RTU)	Metric (SI) Non-metric	U1 U2
	Oil parameterization for water content calculation	Mineral transformer oil Customer specific oil	no code PPMxxx

Order Example

EE364-PA1HM1F13AC2U1

Process connection: 1/2" ISO thread
 Fluid temperature: -40...80 °C (-40...176 °F)
 Filter: Stainless steel, for flow < 1m/s
 Accessory: M12x1 socket connector, for self assembly
 Units: Metric (SI)

Accessories

(For further information, see datasheet "Accessories")

Determination of oil specific parameters	ppm-cal
Modbus configuration adapter	HA011013
EE-PCS Product Configuration Software (free download: www.epluse.com/configurator)	EE-PCS
M12x1 8 pole cable socket for self assembly	HA010704
M12x1 8 pole shielded connection cable, socket/flying leads	
1.5 m (4.9 ft)	HA010322
5 m (9.8 ft)	HA010324
10 m (16.4 ft)	HA010325
Sampling cell with shut-off function, PN40, DN25	HA050109

Clean Rooms | Pharma | Hospital | HVAC | BulkDrugs | Chemicals | Heavy Machinery
 Hydraulics & Vacuum Industry | Green House | Server Room | Confined Space | Cold Storage

Instrukart Holdings

India Toll Free : 1800-121-0506 | Ph : +91 (40)40262020

Mob +91 7331110506 | Email : info@instrukart.com

#18,Street-1A, Czech Colony, Sanath Nagar, Hyderabad -500018, INDIA.



INSTRUKART

YOUR WORLDWIDE INSTRUMENT PARTNER