

2951J, 2951TJ and 2951TMJ Intelligent Photoelectric Smoke Sensors Installation and Maintenance Instructions

This sensor must be installed in compliance with the control panel system installation manual. The installation must meet the requirements of the Authority Having Jurisdiction (AHJ). Sensors offer maximum performance when installed in compliance with the National Fire Protection Association (NFPA); see NFPA 72.

GENERAL DESCRIPTION

Model 2951J, 2951TJ and 2951TMJ are intelligent sensors that combine a state-of-the-art photoelectronic sensing chamber with communications. Models 2951TMJ and 2951TJ combines a photoelectronic sensing chamber and 135°F (57.2°C) fixed temperature heat detector. These sensors are designed to provide open area protection and are intended for use with compatible control panels only.

Two LEDs on each sensor light to provide a local, visible sensor indication. Remote LED annunciator capability is available as an optional accessory (Part No. RA400Z). The sensor will support either FlashScan™ or CLIP (Classic Loop Interface Protocol) SLC communication mode.

Johnson Controls panels offer different feature sets across different models. As a result, certain features of the 2951J, 2951TJ or 2951TMJ may be available on some control panels, but not on others. The possible features available in the 2951J, 2951TJ and 2951TMJ, if supported by the control unit are:

1. The panel controls the LED operation on the sensor. Operational modes are RED blink, RED continuous, GREEN blink, GREEN continuous, and off.
2. The remote output may be synchronized to the LED operation or controlled independent of the LEDs.

SPECIFICATIONS

Operating Voltage Range:	15 to 32 VDC
Standby Current:	300µA @ 24 VDC (one communication every 5 seconds with LED blink enabled)
Max. Alarm Current (LED on):	6.5 mA @ 24 VDC
Operating Humidity Range:	10% to 93% Relative Humidity, noncondensing
Operating Temperature Range:	0° to 49°C (32° to 120°F); 2951J 0° to 38°C (32° to 100°F); 2951TJ and 2951TMJ
Height:	2.0 inches (51 mm) installed in B210LPJ and B501J Bases
Diameter:	6.1 inches (155 mm) installed in B210LPJ Base 4.1 inches (104 mm) installed in B501J Base
Weight:	5.2 oz. (147 gm)

SPACING

Johnson Controls recommends spacing sensors in compliance with NFPA 72. In low air flow applications with smooth ceilings, space sensors 30 feet apart. For specific information regarding sensor spacing, placement, and special applications, refer to NFPA 72 or the *System Smoke Detector Application Guide*, (A05-103-XX) available from Johnson Controls.

Duct Applications: 2951J and 2951TJ are listed for use in ducts. See Duct Applications Guide A05-1004 for details on pendant mount applications.

NOTE: These products are not listed for use inside duct smoke detectors.

WIRING INSTRUCTIONS

All wiring must be installed in compliance with the National Electrical Code, applicable local codes, and any special requirements of the Authority Having Jurisdiction. Proper wire gauges should be used. The installation wires should be color-coded to limit wiring mistakes and ease system troubleshooting. Improper connections will prevent a system from responding properly in the event of a fire.

Disconnect power from the SLC communication line before installing sensors.

1. Wire the sensor base (supplied separately) per the wiring diagram (Figure 1).
2. Set the desired SLC address on the sensor address switches.
NOTE: Some panels support extended SLC addressing. In order to set the sensor above address 99 on compatible systems, carefully remove the stop on the upper rotary switch with thumb or finger as shown in Figure 2.
3. Install the sensor into the sensor base. Push the sensor into the base while turning it clockwise to secure it in place.
4. After all sensors have been installed, apply power to the control unit and activate the communication line.
5. Test the sensor(s) as described in the **TESTING** section of this manual.

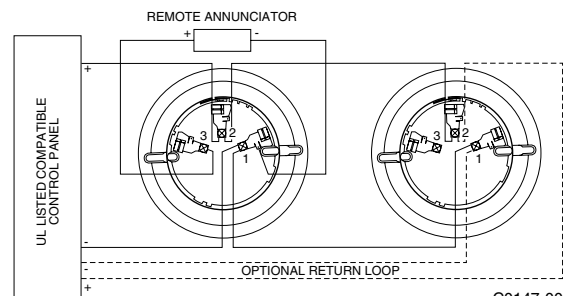

Figure 1. Wiring Diagram

C0147-00

CAUTION

Dust covers provide limited protection against airborne dust particles during shipping. Dust covers must be removed before the sensors can sense smoke. Remove sensors prior to heavy remodeling or construction.

TAMPER-RESISTANCE

Models 2951J, 2951TJ and 2951TMJ include a tamper-resistant capability that prevents their removal from the bracket without the use of a tool. Refer to the base manual for details on making use of this capability.

TESTING

Before testing, notify the proper authorities that the system is undergoing maintenance, and will temporarily be out of service. Disable the system to prevent unwanted alarms.

All sensors must be tested after installation and periodically thereafter. Testing methods must satisfy the Authority Having Jurisdiction (AHJ). Sensors offer maximum performance when tested and maintained in compliance with NFPA 72. The sensor can be tested in the following ways:

A. Functional: Magnet Test (P/N M02-04-01 or M02-09-00)

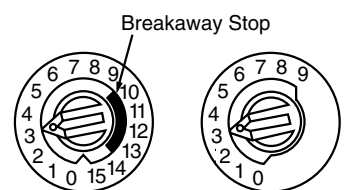

C0162-00

Figure 2. Rotary SLC Address Switches

This sensor can be functionally tested with a test magnet. The test magnet electronically simulates smoke in the sensing chamber, testing the sensor electronics and connections to the control panel.

1. Hold the test magnet in the magnet test area as shown.
2. The sensor should alarm the panel.

Two LEDs on the sensor are controlled by the panel to indicate sensor status. Coded signals, transmitted from the panel, can cause the LEDs to blink, latch on, or latch off. Refer to the control panel technical documentation for sensor LED status operation and expected delay to alarm.

B. Smoke Entry: Aerosol Generator

For 2951TMJ, smoke entry testing should be performed immediately following the magnet test. Magnet test initiates an approximately 10 minute period when the detector's signal processing software routines are not active. Failure to first perform the magnet test will introduce a time delay before the detector alarms.

The GEMINI model 501 aerosol generator can be used for smoke entry testing. Set the generator to represent 4%ft to 5%ft obscuration as described in the GEMINI 501 manual. Using the bowl-shaped applicator, apply aerosol until the panel alarms.

C. Direct Heat Method (Hair dryer of 1000-1500 watts). 2951TJ and 2951TMJ only.

Direct the heat toward either of the side thermistors. Hold the heat source about 12 inches from the detector in order to avoid damage to the plastic. The detector will reset only after it has had sufficient time to cool.

Both smoke and heat detection testing are recommended for verifying system protection capability.

A sensor that fails any of these tests should be cleaned as described under **CLEANING**, and retested. If the sensor fails after cleaning, it must be replaced and returned for repair. When testing is complete, restore the system to normal operation and notify the proper authorities that the system is back in operation.

HIGH SENSITIVITY SETTING

The use of the 0.2% to 0.5% per foot sensitivity setting requires a 90 day test period to ensure that the detector's environment is suitable for this setting. The following steps must be followed to meet Johnson Controls and UL requirements for this high sensitivity application:

1. Each detector intended for 0.2% to 0.5% per foot alarm application shall have its initial alarm setting set for 0.5% obscuration per foot alarm level. The initial pre alarm setting for the detector shall be set to the intended alarm setting of the system. Pre alarm shall be set for non latching operation.
2. Detectors set at 0.2% to 0.5% per foot are intended for use in smoke-free, environmentally controlled applications, such as computer rooms and clean rooms. In order to determine if an environment is suitable for installation, the detectors shall be operated continuously for 90 days with all environmental factors, including temperature, humidity, air flow, occupancy, etc., similar to the intended application for these detectors. An electronic history file or printer shall be used to record all events associated with the detectors under testing.
3. At the end of 90 days, the results of the test shall be inspected by an authorized Johnson Controls representative or the end user, if trained by an authorized Johnson Controls representative. If no alarms or pre alarms are recorded for the detectors under testing, the system may be set to the tested pre alarm level in the 0.2% to 0.5% per foot range.

CLEANING

Before removing the detector, notify the proper authorities that the smoke detector system is undergoing maintenance and will be temporarily out of service. Disable the zone or system undergoing maintenance to prevent unwanted alarms.

1. Remove the sensor to be cleaned from the system.
2. Remove the sensor cover by pressing firmly on each of the four removal tabs that hold the cover in place.
3. Vacuum the screen carefully without removing it. If further cleaning is required continue with Step 4, otherwise skip to Step 7.
4. Remove the chamber cover/screen assembly by pulling it straight out.
5. Use a vacuum cleaner or clean, compressed air to remove dust and debris from the sensing chamber.
6. Reinstall the chamber cover/screen assembly by sliding the edge over the sensing chamber. Turn until it is firmly in place.
7. Replace the cover using the LEDs to align the cover and then gently pushing it until it locks into place. Make sure that the thermistors do not become bent under the cover on the 2951TJ and 2951TMJ.
9. Reinstall the detector.
10. Test the detector as described in TESTING.
11. Reconnect disabled circuits.
12. Notify the proper authorities that the system is back on line.

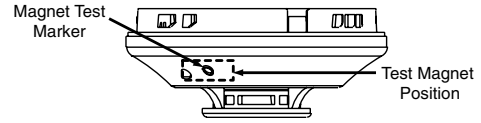
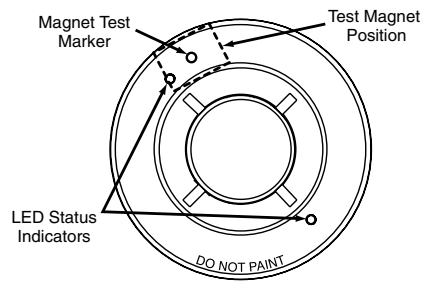

Figure 3.

C0163-00

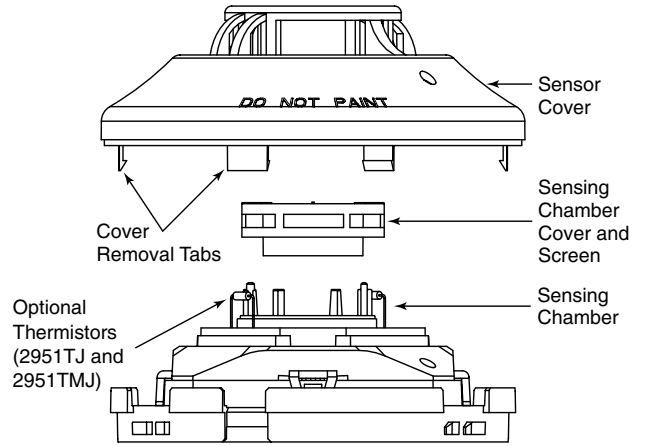

Figure 4.

C0119-00

Please refer to insert for the Limitations of Fire Alarm Systems

FCC Statement

This device complies with part 15 of the FCC Rules. Operation is subject to the following two conditions: (1) This device may not cause harmful interference, and (2) this device must accept any interference received, including interference that may cause undesired operation.

Note: This equipment has been tested and found to comply with the limits for a Class B digital device, pursuant to Part 15 of the FCC Rules. These limits are designed to provide reasonable protection against harmful interference in a residential installation. This equipment generates, uses and can radiate radio frequency energy and, if not installed and used in accordance with the instructions, may cause harmful interference to radio communications. However, there is no guarantee that interference will not occur in a particular installation. If this equipment does cause harmful interference to radio or television reception, which can be determined by turning the equipment off and on, the user is encouraged to try to correct the interference by one or more of the following measures:

- Reorient or relocate the receiving antenna.
- Increase the separation between the equipment and receiver.
- Connect the equipment into an outlet on a circuit different from that to which the receiver is connected.
- Consult the dealer or an experienced radio/TV technician for help.

Clean Rooms | Pharma | Hospital | HVAC | BulkDrugs | Chemicals | Heavy Machinery
Hydraulics & Vacuum Industry | Green House | Server Room | Confined Space | Cold Storage

Instrukart Holdings

India Toll Free : 1800-121-0506 | Ph : +91 (40)40262020

Mob +91 7331110506 | Email : info@instrukart.com

#18,Street-1A, Czech Colony, Sanath Nagar, Hyderabad -500018, INDIA.

