

M SR -Sensitron Transmitter Series XT-21-34XXP for Combustible Gases for Zone 1 and 2

DESCRIPTION

Microprocessor based analog gas transmitter with 4 – 20 mA output signal for monitoring the ambient air and detecting flammable gases and vapours in the lower explosion level (LEL) by means of a catalytic sensor (pellistor). The calibration for types without LCD display is possible via the handheld calibration keypad XT.S/CKD. The types with LCD display have a non intrusive magnetic calibration feature for easy calibration without opening the instrument and declassifying the area. The gas transmitter is available with EEx-d protection for Ex zone 1 and 2, or with EEx-n protection for Ex zone 2.



APPLICATION

The gas transmitter series XT-21-11XX are designed for the detection of toxic gases within a wide range of industrial applications. Due to the 4 to 20 mA analog output signal the transmitter is compatible to any electronic analog control, DDC/PLC control or automation system (e.g. PolyGard series MGC and DGC by MSR-E).

Optionally the MSR-Sensitron Transmitter is available with LCD display, relay or open collector board and RS 485 serial interface.



FEATURES

- ATEX certifications MSR electronic/Sensitron
- Continuous monitoring
- 10 bit microprocessor
- Self diagnostic procedure
- Zero point tracking
- Watch dog switch
- Easy calibration (zero, span and 4-20mA adjustment)
- 4 to 20mA proportional or three-step (0, 10 and 20 mA) output
- Reverse polarity protected
- Overload-proof
- LCD display with status LED (optional)
- One-relay board (optional)
- Three-relay board (optional)
- Open collector board (optional)
- RS 485 serial bus (optional)

SPECIFICATIONS

Electrical	
Power supply	12 - 24 VDC -20% +15%
Power consumption (at 12 VDC)	90 mA, max. 130 mA
Output signal	4 to 20 mA proportional on 200 Ω or 0-10-20 mA
Control unit	Microprocessor 10 bit (resolution 1024 points)
Digital filter	Variable average on the sampled values
Visual indications	Flashing LED
LCD display (optional)	4 digits; 5 status LED
Serial output (optional)	Serial RS-485
One-relay output (optional)	Max. 24 VAC/DC, 1 A
Three-relay output (optional)	Max. 24 VAC/DC, 1 A
Two open collectors (optional)	Max. 24 VDC, 20 mA
Sensor Performance	
Detected gases	Combustible gases
Sensor element	Pellistor
Measuring range	0-100 %LEL
Response time	$t_{90} \leq 15-30$ sec.
Accuracy	± 5 % of range or 10 % of reading
Repeatability	± 5 % of range
Warm-up time	300 sec.
Stabilisation time	120 sec.
Zero-point drift	Auto zero drift compensation
Operating Environment	
Humidity	20 to 90 % RH / 40 °C (104 °F)
Operating temperature	-10 °C to + 60 °C (14 °F to + 122 °F)
Storage temperature	-25 °C to + 60 °C (-13 °F to + 140 °F)
Pressure range	800 to 1100 mBar (80 to 110 kPa)
Air velocity	< 6m/sec.
Physical characteristics	
Enclosure material / color	Aluminum Die Cast or SS/ Blue
Dimensions EEx-d (HxWxD)	200 x 105 x 90 mm (7.87 x 4.13 x 3.54 In.)
Dimensions EEx-n (HxWxD)	160 x 106 x 62 mm (6.30 x 4.17 x 2.44 In.)
Weight (without options)	EEx-d: 0,9 kg (2.0 lbs.) EEx-n: 0,8 kg (1.8 lbs.)
Protection class	EEx-d: IP65 EEx-n: IP55
Mounting	Wall mounting (sensor head downwards)
Cable entry	1 x NPT ¾ In.
Wire connection	Screw type, min. 0.25 (24 AWG) max. 2.5 mm ² (14AWG)
Wire length	Max. working resist. 200 Ω (= wire resistance+ controller input resistance)
ATEX Marking	CE 722 ^{Ex} II 2G EEx d IIC T6 CE 722 ^{Ex} II 3G EEx nA IIC T6
EC Type Certification	CESI 01ATEX053 (Electrical Safety Requirements EEx-d vers.) CESI 03ATEX339 (Electrical Safety Requirements EEx-n vers.) CESI 02ATEX084 (Performances; flammable gas version)
Sensor head	CESI 01ATEX013U or CESI 01ATEX066U
Guidelines	EN50014, E50018; EN50021 (Electr. Saf. Req. EEx-d and -n) EN 61779-1/4 (Performances)
Warranty	One year on material and workmanship

ORDERING INFORMATION

XT21-34XX-PXX-XXX

Options

- 1XX One-relay board
- 2XX Open collector board
- 3XX RS-485 bus
- X1X Three-relay board**
- XX1 Factory calibration

Type / Protection

- PXX Pellistor sensor
- PDX EEx-d (zone 1) protection
- PNX EEx-n (zone 2) protection*
- PXL LCD display***

Gas type

00	Methane	CH ₄
02	LPG (liquefied petroleum gas)	
05	Acetylene	C ₂ H ₂
08	Ammonia	NH ₃ (0-100%LEL)
09	Ammonia	NH ₃ (2000 ppm)
10	Ethylene	C ₂ H ₄
12	Ethylene Oxide	ETO
20	Ethane	C ₂ H ₆
25	Ethyl Alcohol	C ₂ H ₅ OH
27	Ethyl-Acetate	CH ₃ COOC ₂ H ₅
35	n-Hexane	C ₆ H ₁₄
40	Hydrogen	H ₂
50	Methanol	CH ₃ OH
58	Methyl Ethyl Ketone	C ₄ H ₈ O
60	n-Butane	C ₄ H ₁₀
65	ISO-Butane	C ₄ H ₁₀
68	ISO Butyl Alcohol	C ₄ H ₁₀ O
72	Cyclopentane	C ₅ H ₁₀
75	n-Pentane	C ₅ H ₁₂
76	Iso-Pentane	C ₅ H ₁₂
78	Propene	C ₃ H ₆
80	Propane	C ₃ H ₈
82	Iso Propyl Alcohol	C ₃ H ₈ O
84	Propyl Alcohol	C ₃ H ₈ O
85	Acetone	(CH ₃) ₂ CO
88	Acetic Acid	C ₂ H ₄ O ₂
90	Toluene	C ₇ H ₈
91	n-Heptane	C ₇ H ₁₆
92	Styrene	C ₈ H ₈
93	Xylene	C ₈ H ₁₀
94	Trimethylbenzene	C ₉ H ₁₂
95	Nonane	C ₉ H ₂₀
96	Petrol Vapours	
98	JP8	

* Only available for Methane, LPG, n-Butane, Propane and Petrol vapours

** Not available with LCD display

*** Not available with three-relay board

Example: Transmitter for Methane detection, EEx-d protection, LCD display, one-relay board, factory calibration

Ordering Number: XT21-3400-PDL-101

CONNECTING DIAGRAM

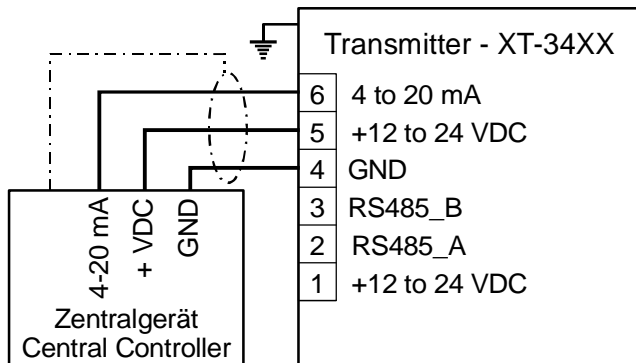

Clean Rooms | Pharma | Hospital | HVAC | BulkDrugs | Chemicals | Heavy Machinery | Hydraulics | Vacuum Industry
Green House | Server Room | Confined Space | Cold Storage

Instrukart Holdings

India Toll Free : 1800 -121-0506 | Ph : +91 (40)40262020

Mob +91 7331110506 | Email : info@instrukart.com

#18,Street-1A, Czech Colony, Sanath Nagar, Hyderabad -500018, INDIA.