



GREYSTONE ENERGY SYSTEMS INC

CARBON MONOXIDE DETECTOR CMD5B Series

The CMD Series carbon monoxide detector uses an electrochemical sensor to monitor the carbon monoxide level and outputs a field-selectable 4-20 mA or voltage signal. The voltage signal may also be set to 0-5 or 0-10 Vdc. The sensing range and output may be scaled to either 100, 150, 300, 400 or 500 ppm via the on-board menu. A front panel LCD is standard to ensure easy setup and operation. It is available in either space or duct mount configurations.

Other standard features include a back light for the LCD, a front panel test switch, status indication and an alarm buzzer. The test function may also be controlled remotely with a digital input signal. The on-board menu allows for local configuration of all device parameters.

Optional features include one or two alarm relays and/or RS-485 network communications configured for either ModBus or BACnet protocol.



PART NUMBER SELECTED

SPECIFICATION:

Sensor Type	Electrochemical
Sensor Agency Approvals	Sensor is UL Recognized Component for ANSI/UL-2034, UL-2075, E240671
Measurement Range	0-100, 150, 300, 400, or 500 PPM (Selectable)
Accuracy	±5 PPM or 5% of reading (whichever is greater)
Accuracy rated	0° to 50°C (32° to 122°F), 15 to 95% RH
Life Expectancy	5-7 years in air
Typical Coverage Area	700 m ² (7500 ft ²) or 15 m (50 ft) radius
Operating Conditions	-20° to 50°C (-4° to 122°F), 15 to 95% RH, 0.9 to 1.1 atm
Sample Method	Diffusion or flow through sample tube for duct mounted models
Stability	<5% signal loss/year
Response Time	<35 seconds for 90% step change
Power Supply	24 Vdc ± 20% or 24 Vac ± 10% (non-isolated half-wave rectified)
Consumption	100 mA max. with all options on
Protection Circuitry	Reverse voltage protected and output limited
Output Signal	4-20 mA (Active), 0-5 or 0-10 Vdc (Selectable)
Output Drive at Capability	450 ohms max for current output, 10 Kohms min for voltage output
Output Resolution	10 bit PWM (±0.4 ppm)
LCD Display	Displays PPM and menu parameters 1 PPM resolution, 35 mmW x 15 mm H (1.4" x 0.6") Alpha-numeric 2 line X 8 character with backlight
Status LED	2 color (red/green) on front panel
Test Switch	Performs I/O tests, front panel and remote connection
Buzzer Alarm	85 db @ 10 cm
Buzzer Trip Point	Programmable 20-500 ppm in 10 ppm increments
Buzzer Delay	Programmable 0-10 minutes in 1 minute increments

PRODUCT SELECTION INFORMATION:

MODEL	Product Description
CMD5B	Carbon Monoxide Detector

CODE	Options
4	Space ABS
5	Duct ABS

CODE	Circuit Board Relay
000	No relay
100	One Relay
110	Two Relays

CODE	Optional Communications
BAC	BACNet Communications
MOD	Modbus Communication

Greystone Energy Systems, Inc. reserves the right to make design modifications without prior notice.

Optional Relay Output	One or two Form C contact (N.O. and N.C.) 5 amps @ 250 Vac, 5 amps @ 30 Vdc, p.f. = 1 Relay 1 Trip Point - Programmable 20-500 PPM in 10 PPM increments Relay 2 Trip Point - Programmable 20-500 PPM in 10 PPM increments Relay Hysteresis - Programmable 10-100 PPM in 5 PPM increments Relay Delay - Programmable 0-10 minutes in 1 minute increments
Optional Communications	BACNet or Modbus (Refer to installation instructions for full details)
Wiring Connections	Screw terminal block (14 to 22 AWG)
External Dimensions	Space, 145 x 101 x 64mm (5.7" w x 4" h x 2.5" d) Duct, 145 x 101 x 240mm, (5.7" w x 4" h x 9.5" d) includes probe
Enclosure Ratings	Space (4) - ABS - UL94-V - IP65 (NEMA 4X) Duct (5) - ABS - UL94-V - IP65 (NEMA 4X)
Field Calibration	By applying calibration gas standards (Contact Greystone for calibration kit)
Accessories	Calibration kit, model# CMD-CALKIT-GS

TYPICAL INSTALLATION:

For complete installation and wiring details, please refer to the product installation instructions.

The CMD Space can be mounted directly to a wall using the 4 mounting holes provided.

The CMD Duct is installed through the side of the duct, and fastened securely to the duct through the mounting holes provided.

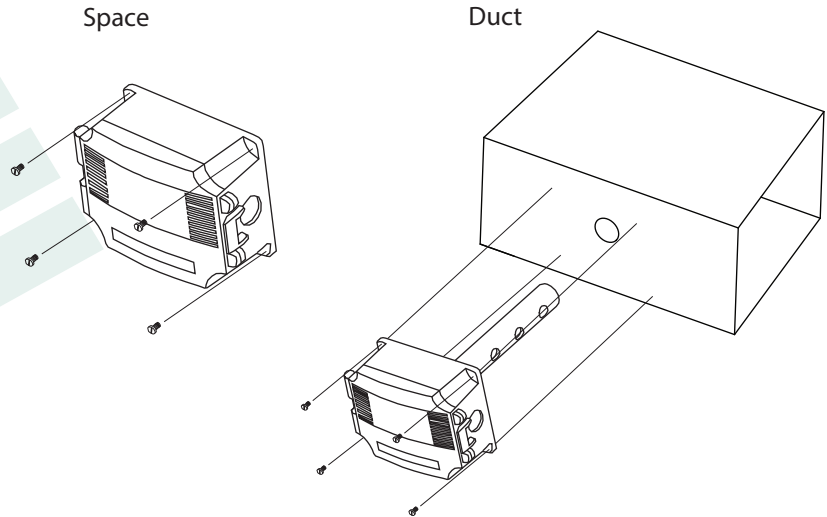

DIMENSIONS:

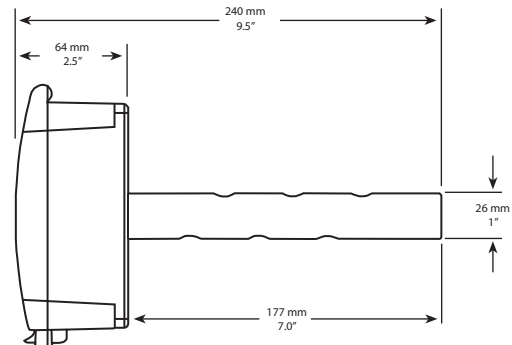
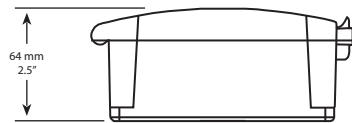
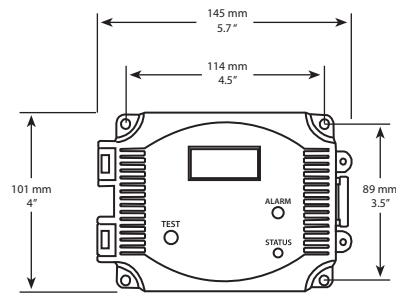
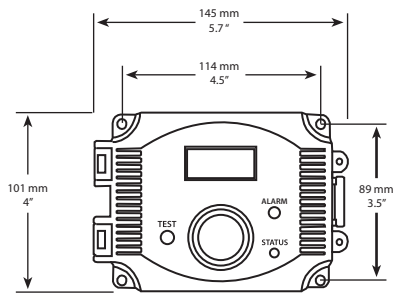

GREYSTONE

ENERGY SYSTEMS INC

Greystone Energy Systems, Inc.
150 English Drive, Moncton,
New Brunswick, Canada E1E 4G7

(506) 853-3057 Fax: (506) 853-6014
North America: 1-800-561-5611
e-mail: mail@greystoneenergy.com
www.greystoneenergy.com

RoHS
COMPLIANT



Greystone Energy Systems Inc. is one of North America's largest ISO registered manufacturers of HVAC sensors and transmitters for Building Automation Management Systems.

We have conscientiously established a worldwide reputation as an industry leader by maintaining leading-edge design technology, prompt technical support, and a commitment to on-time deliveries. We take pride in our Quality Management System which is ISO 9001 certified, assuring our customers of consistent product reliability.

GREYSTONE HAS AN ISO 9001 REGISTERED QUALITY SYSTEM