

## Explication and Features

SP2nd is an economical gas detector that can be operated continuously for two years without replacement of gas sensor to protect workers from the disasters caused by the oxygen deficiency or toxic gas poisoning. Measure one gas continuously and display its concentration and raise an alarm when a risk occurs.

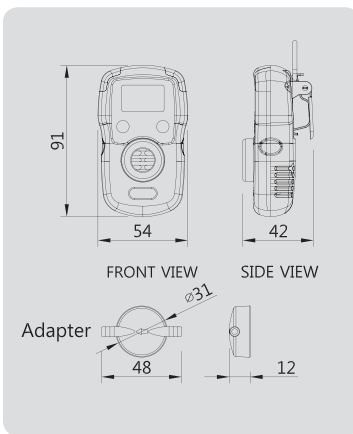

- Rubber material case for the shock protection
- The excellent water proof/dust proof structure
- High performance audible, visual, vibration alarm
- Setting 1st, 2nd alarm
- Automatic checking of the sensor trouble
- Data logging
- Disposable type (Under development)

## Applications

Steelworks, Petrochemical plant, Shipbuilding yard, Sewage treatment plant, Mine, Power supply works, Hermetically sealed area (manhole, tank)



## Specification

Model	SP2217	SP2227	SP2257	SP2277	SP2297	SP22N7
Measuring gas	O <sub>2</sub>	CO	SO <sub>2</sub>	H <sub>2</sub>	H <sub>2</sub> S	NH <sub>3</sub>
Measuring type	Diffusion Type					
Measuring method	Electrochemical cell					
Measuring range	0~30%	0~500ppm	0~20ppm	0~1000ppm	0~100ppm	0~100ppm
Sensor life time	> 18Month	> 2 year	> 2 year	> 2 year	> 2 year	> 2 year
Response time	<15sec/90%scale	<30sec/90%scale	<35sec/90%scale	<75sec/90%scale	<30sec/90%scale	<60sec/90%scale
Accuracy	±3%/Full scale					
Resolution	0.1%vol	1ppm	1ppm	1ppm	0.1ppm	1ppm
Parameter Control	Front 2 switch(calibration, maintenance, alarm setting)					
Operation mode display	Visual : Digital LCD display, Trouble RedLED Audible : buzzer(90dB @ 10cm)					
Measuring value display	LCD Display(3-digit)					
Alarm display	"Visual : alarm & status icon, Trouble RedLED Audible : buzzer"					
Alarm level set	Programmable within detection range					
Data Log	Event Log : 20 Data					
Mounting type	Belt Clip					
Program set mode	Alarm value(1,2 alarm) time Set Calibration density setting					
Operating temperature	-20℃ ~50℃					
Operating humidity	5% to 95% RH(Non-condensing)					
Operating power	CR2 Lithium Battery 3V					
Battery life time	CR2 Battery(3.0v) : 1.2year, At 8hours use of a day					
Material	PC / TPE					
LCD size	27(W) × 17.5(H) mm					
Dimensions	54(W) × 91(H) × 42(D) mm					
Weight	120g (Including Battery)					
Approval	Ex ia IIC T4 IP67(KGS, ATEX)					

Clean Rooms | Pharma | Hospital | HVAC | BulkDrugs | Chemicals | Heavy Machinery  
Hydraulics & Vacuum Industry | Green House | Server Room | Confined Space | Cold Storage

## Instrukart Holdings

India Toll Free : 18000-121-0506 | Ph : +91 (40)40262020

Mob +91 7331110506 | Email : info@instrukart.com

#18,Street-1A, Czech Colony, Sanath Nagar, Hyderabad -500018, INDIA.



# INSTRUKART

YOUR WORLDWIDE INSTRUMENT PARTNER