

Winters Digital Vacuum Gauge



Description & Features:

- Simple 2 button operation
- Reset to zero feature
- Backlight turns ON when ON/OFF button is pressed and with pressure changes
- Option for display to remain continuously ON
- Peak pressure indication option
- 316L welded diaphragm seal
- Standard Rubber boot
- ASME B40.100 compliant
- $\pm 0.5\%$ Accuracy
- 1 year warranty (On Manufacturing defects, no warranty on breakage or mishandling)

Applications:

- Ideal for commercial and industrial application in both test measurement and general purpose



Specifications

Case Size	2.5" (63mm)
Case Material	ABS (IP64)
Rubber Boot	Silicone rubber (IP65) overall cover
LCD Display	2" x 3/4" (48mm x 16mm) with engg. unit Display
Connection	1/4" NPT 304SS
Sensor	316L welded, Piezo
Operating Life	1 million cycles
Power Supply	2 x AAA battery (1.5V)
Battery Life	2 yrs (auto shut-off mode)
Power Mode	Auto or manual shut-off
Range	4 digits 0 to 760 mm.Hg / 0 to 14.5 psi / 0 to 1013 mBar
Resolution	1 digit for mm.Hg Engg.unit/0.1 psi for psi engg.units
Pressure Unit Selection	psi, mH ₂ O, mmHg, mbar, kPa unit selection from front keys
Operation Mode	Continuous process pressure reading or peak pressure reading
Response Time	≤ 3 Hz display refresh rate
Proof / Burst Pressure	More than +1 Bar pressure
Operating / Storage Temperature	14°F to 122°F (-10°C to 50°C) -4°F to 167°F (-20°C to 75°C)
Accuracy	$\pm 0.5\%$ of readings
Optional Ranges	Contact Store : Ranges : -1000 to +1000 mBar -1000 to +3000 mBar -14.5 psi to +43.5 psi

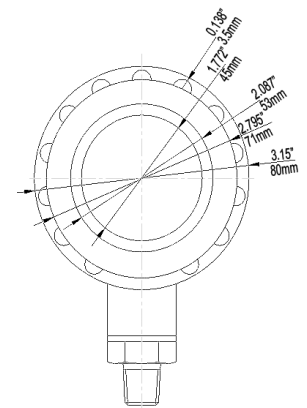

DPG SERIES
with rubber cover

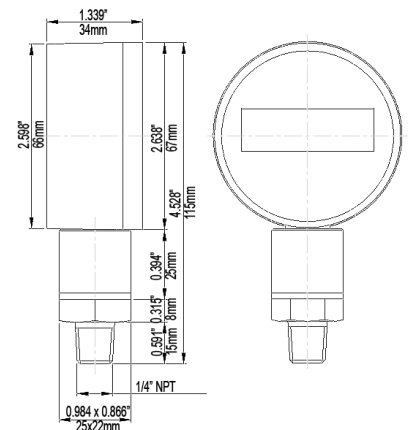

DPG SERIES
without rubber cover

Clean Rooms | Pharma | Hospital | HVAC | BulkDrugs | Chemicals | Heavy Machinery
Hydraulics & Vacuum Industry | Green House | Server Room | Confined Space | Cold Storage

Instrukart Holdings

India Toll Free : 1800-121-0506 | Ph : +91 (40)40262020

Mob +91 7331110506 | Email : info@instrukart.com

#18,Street-1A, Czech Colony, Sanath Nagar, Hyderabad -500018, INDIA.

